

MOTOR DRIVER

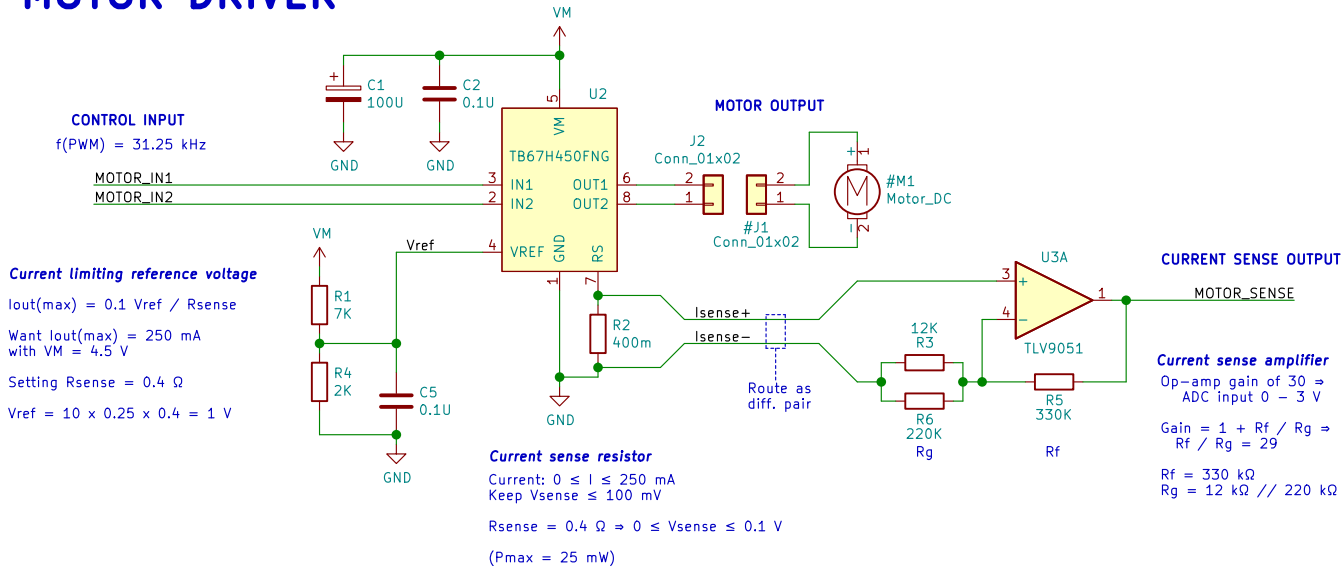

POWER

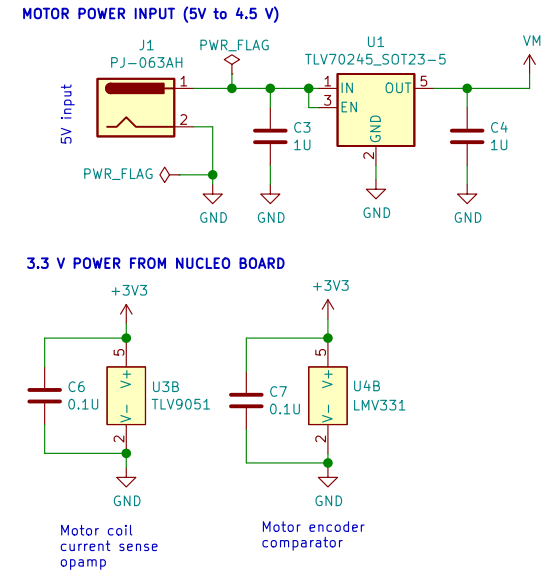

MOTOR ENCODER

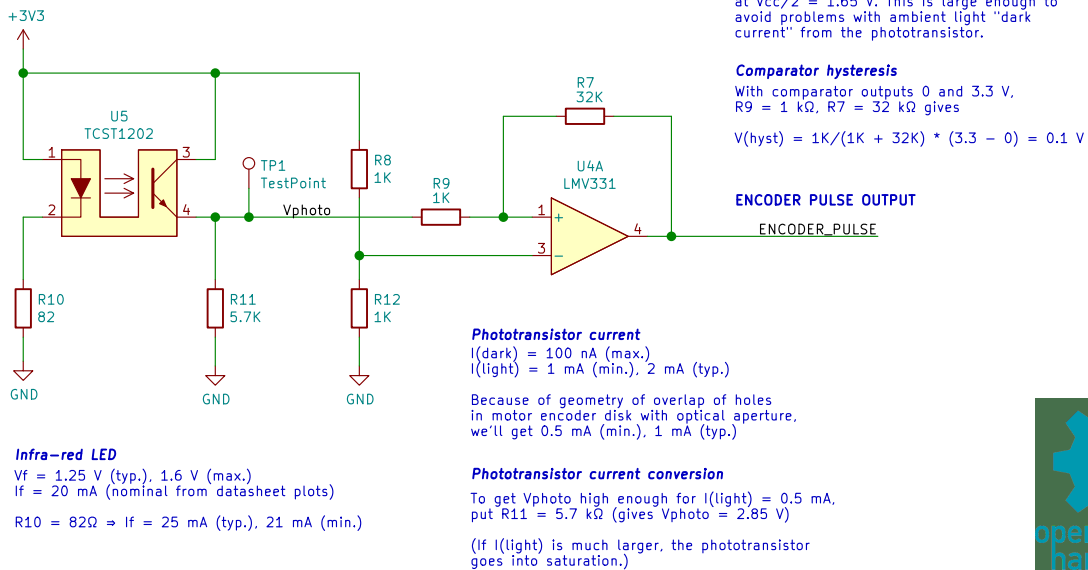

NUCLEO CONNECTIONS

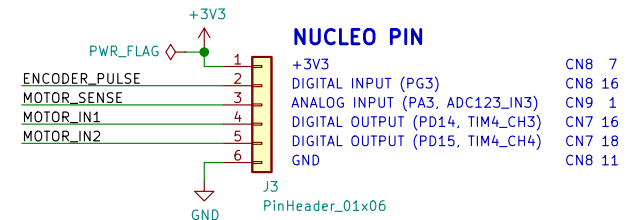

Motor driver and encoder prototype board
 Part of the Mini-Mapper project
 Designed for AISLER 2-Layer Service

Sheet: /
 File: motor-board.sch

Title:

Size: A4
 KiCad E.D.A. kicad 5.1.6

Date:

Rev: 1
 Id: 1/1